

INSTALLATION ON WELD PLATES

STAUFF weld plates are available for the following Series:

- Standard-Series
- Heavy-Series
- Twin-Series
- Special Clamps

For best alignment of STAUFF clamps it is recommended to mark their location first. Weld plates into position, push on bottom half of clamp, install pipe, mount top half of clamp and cover plate and bolt unit together.

In order to avoid damage to the clamp bodies it is recommended to mount the plastic clamp bodies after having welded the weld plates into position.

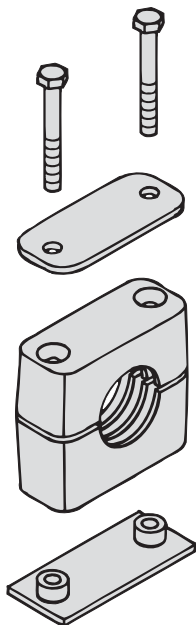

INSTALLATION ON MOUNTING RAILS

STAUFF mounting rails can be used with the following Series:

- Standard-Series
- Heavy-Series (Group 3S – 6S)
- Twin-Series
- Special Clamps

STAUFF mounting rails are available in four different height sizes.

The rails are either welded or bolted to the supporting structure.

For Standard- and Twin-Series insert hexagon rail nut and turn to lock.

For Heavy-Series slide in rail nut.

Push on bottom half of clamp, install pipe, mount top half of clamp, cover plate and bolt unit together.

Clamp units can be adjusted before being firmly bolted.

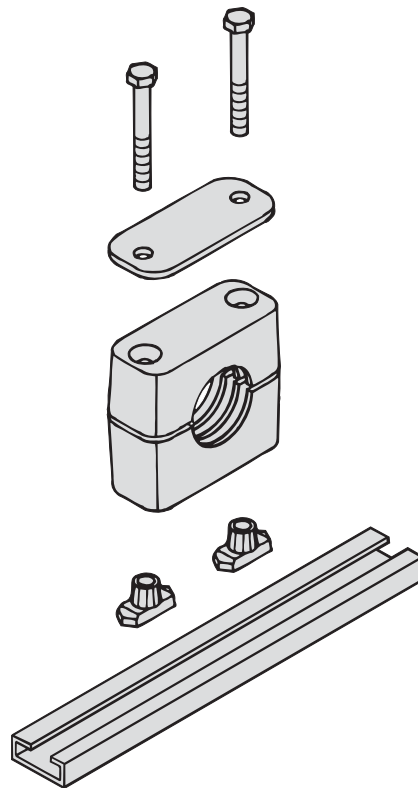

MULTI-LEVEL ASSEMBLY

STAUFF multi-level pipe clamps permit easy stacking of several tubes or pipes of the same group.

(Twin-Clamps group 2 – 5 allow stacking of different group sizes.)

The clamps are connected by stacking bolts (AF).

Safety plates (SIG/SIP/SI) inserted between the clamps prevent stacking bolts from turning.

STAUFF stacking assembly can be fitted to weld plates or to rails.

